

## **Format for 'Research Plan'**

**(For categories: Environmental, Life and Physical Sciences.  
This is not for Engineering Science category)**

**The Research Plan should include the following:**

**a. Introduction (in a few lines):**

Specify the area of research and subject. Briefly give the need for doing this research. What would be the scope of outcome of the research.

**b. Selection Of Problem and Background Information:**

A brief synopsis of the backgrounds that supports your research problem and explains why this research is important and if applicable, explains any societal impact of your research.

**c. Objective:**

Clearly state **Research Problem**, What do you want to find out? What is your question?

Why the problem has to be solved?

What is the methods of approach for carrying out research.

Clearly state the variables involved in the study.

Clearly state How the '**cause and effect**' will be studied by varying one variable (Independent variable) to measure the dependent variable while keeping other variables constant.

What is the control in your study while carrying out measurements in the samples under study.

**d. Hypothesis:**

What do you think will happen? Hypothesis is educated guess or logical explanation that could be tested and forecasts how one variable (independent) can affect a second variable (dependent).

**e. Procedure:**

How will you conduct your investigation? Detail all procedures and experimental design including methods for data Collection.

**Proposed TABLES for data collection shall be given.**

**YOU NEED NOT GIVE DATA.**

(Use FUTURE TENSE to describe the details of the method or procedure

May be written stepwise, in sections, or in phases.

Detail the procedure and experimental design.

May use diagrams or flow charts, etc.

STAY AWAY from personal pronouns: "I will...We will...Next I will...etc."

Use metric measurements. Include concentrations, quantities and major equipment.

Include a copy of a questionnaire, survey, or test if part of the study)

- f. **Risk and Safety:** Identify any potential risks and safety precautions needed.
- g. **Data Analysis:** Describe the procedures you will use to analyze the data/results.(State the procedures that WILL BE USED to analyze the data that WILL BE collected to answer the question or hypothesis.)

USE the FUTURE TENSE.

DO NOT give results.

**DO NOT give a conclusion. The research plan states WHAT WILL BE DONE.**

- g. **Bibliography:** List major references (e.g. science journal articles, books, internet sites) from your literature Review.  
Do not rely only on Internet resources. Internet resources should be reliable. But also use science journals, books, magazines, newspapers, etc.
- Use a proper bibliography format (MLA or AP style or other format) for journals, books, magazines, newspapers and Internet resources.

**Example from a journal article:**

Meise CJ, Johnson DL, Stehlik LL, Manderson J, Shaheen P. 2003. Growth rates of juvenile Winter Flounder under varying environmental conditions. **Trans Am Fish Soc.**, 132(2):225-345.

**Example from a book chapter:** McDaniel TK, Valdivia RH. 2005.

New tools for virulence gene discovery. In: Cossart P, Boquet P, Normark S, Rappuoli R, editors. **Cellular Microbiology**. 2nd ed. Washington (DC): ASM Press. p. 473-488.

**Example from an electronic article:**

Hong P, Wong W. 2005. GeneNotes: a novel information management software for biologists. BMC Bioinformatics [Internet]. [Cited 2007 July 24]; 6:20. Available from: HYPERLINK

"<http://www.biomedcentral.com/1471-2105/6/20>

"<http://www.biomedcentral.com/1471-2105/6/20>

## Research Plan (Sample)

## **Title : Do citrus fruits impact a saltwater battery ?**

### **a. INTRODUCTION:**

This research in **electrochemistry** involves the study of variation in energy out-put of **batteries** as the nature of electrolytic solution is varied.

This research contemplates to check the utility of waste fruits which also contain electrolytes as the alternative source of electrolytes in batteries.

This research work would find out which fruit juice is more effective as an electrolytic solution in batteries.

### **b. SELECTION OF PROBLEM AND BACKGROUND INFORMATION:**

Climate change is making its impact felt world-wide. Yet carbon dioxide emissions keep increasing. When we burn coal to produce electricity, large quantities of carbon dioxide are expelled into our atmosphere. Non-conventional energy sources are of dire need for ever.

Can anyone imagine how our life would change if batteries did not exist? Batteries power many things around us; including cell phones, wireless video game controllers, and smoke detectors.

Many of us know, we can make a battery out of a piece of fruit.

Generally, any material having ions can originate electricity when suitable electrode is provided.

### **c. OBJECTIVE OF RESEARCH :**

#### **Statement of the Problem:**

Saltwater based batteries could be the best economical energy source for homes and factories. In the same way, acidic juices, citric fruits etc. can also conduct electricity.

But how about teaming up fruits with saltwater? Will there be any impact?

The question is, "To what extent is it possible to increase their current generating efficiency by adding waste citrus fruit juices?"

**Plan for the experimental design:**

To measure voltage and current (dependent variable) as function of different Fruit juices mixed with salt solution in a constant proportion (independent variable)

To measure voltage and current (dependent variable) for a particular fruit mixed with salt solution in a constant proportion as function of different types of mechanical treatment (independent variable)

**d. HYPOTHESIS**

*Lemon-Salt Combo will be the best battery among all other fruit-salt combos.*

**e. EXPERIMENTAL PROCEDURES**

**DESIGN OF STUDY:**

**INDEPENDENT VARIABLE:**

Nature of electrolyte (fruit combo)

**DEPENDENT VARIABLE:**

Voltage and Current flow

**CONTROLLED VARIABLES:**

Temperature  
Concentration of solution  
Mechanical Treatment of solution

**MATERIALS:**

Copper electrodes (4)  
Zinc electrodes (4)  
Alligator clip leads (4 sets)  
Digital multimeter with test leads  
Piezoelectric buzzer  
Glass tumblers (4)  
Rock salt (Sodium Chloride)  
Citrus fruits (Lemon, Orange, Tomato)  
Measuring cup, metric – 100ml, 50  
Bowl for weighin  
Digital balance

Paper Straw  
Timer or watch with second hand  
Lab notebook

### **PROCEDURE:**

Label the 4 glass tumblers as Salt water, Salt water + lemon, Salt water + orange, Salt water + tomato

Make a data-table accordingly

### **Preparation of electrolytes:**

#### **A. Saltwater electrolyte:**

Place the weighing cup on the digital scale and tare the scale.

Weigh 20 grams of rock salt (NaCl).

Fill the beaker with 400mL of tap water using measuring cup.

Add the weighed salt to the water in the beaker.

Stir the solution with a clean spoon **until all salt is dissolved.**

Pour 90 ml in all the 4 glasses.

The amount of salt needed to attain the concentrated (saturated) solution may be decided after a trial and error.

#### **B. Fruit electrolytes:**

Select the citrus fruits which are more acidic –lemon, orange and tomato.

Collect some fresh juice from the fruits in the concentrated form (without adding water) with the help of hand-juicer.

Filter for any seeds.

#### **C. Fruit-Salt Combo:**

Prepare fruit-salt combo by mixing fruit juice with saltwater as follows:

Measure 10 ml of lemon juice and pour into the glass labelled SW+Lemon.

Measure 10 ml of orange juice and pour into the glass labelled SW+Orange.

Measure 10 ml of tomato juice and pour into the glass labelled SW+Tomato.

### **Experimental Setting up:**

Four Copper and Four Zinc electrodes will be taken.

Label each of the 4 Copper and 4 Zinc as 1,2,3,4. Weigh them separately and enter into the tabulation.

Observe the appearance, surface roughness, lustre and take a picture of the electrodes before beginning the project and record in **TABLE: 1.**

This is necessary for the comparison of the same at the end.

In each of the glasses, insert zinc and copper electrode respectively. Place them on opposite sides of the glass so they face each other. The electrodes should remain in the electrolyte taken in the glasses throughout the entire experiment.

### Measuring Voltage and Current Output

The electrodes will be connected as shown in the diagram to a multimeter. Record the **open-circuit voltage** (the voltage across both electrodes when no current is flowing) and the **short circuit current** (the current when the battery's electrodes are shorted together) for each of the batteries under THREE different experimental conditions.

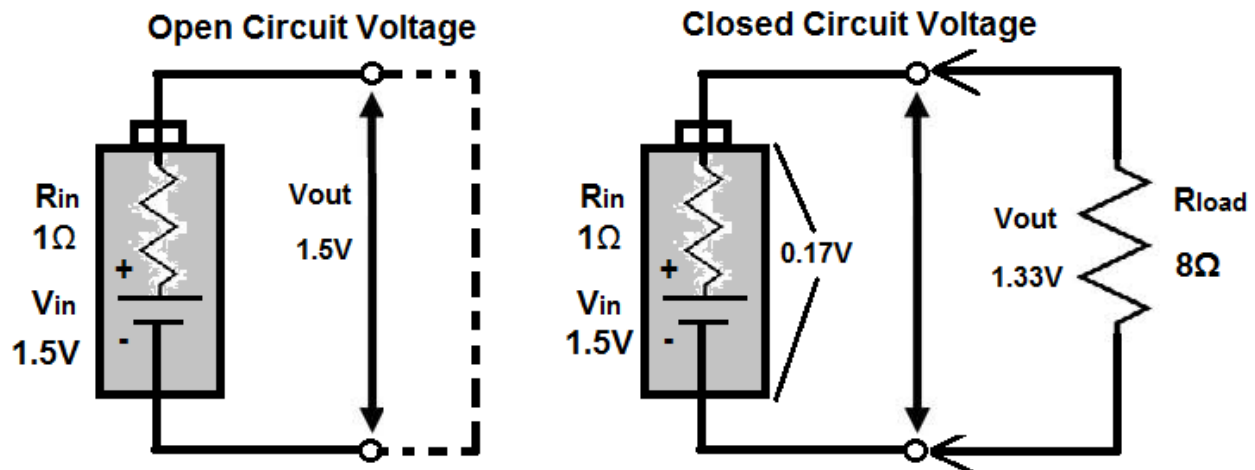

### EXPERIMENTAL PLAN :

It is planned to measure open-circuit voltage and short-circuit current for **THREE different electrolytes** under **THREE different experimental conditions**

#### Experimental conditions:

##### a) Without any mechanical treatment:

The open-circuit voltage and short circuit current of each of the batteries will be measured.

Connect the multimeter and set the dial to measure in the 20 V range to record the open circuit voltage.

Then change the multimeter dial to measure in the 200mA range to record the short-circuit current for every minute over 3 minutes and record in the Data **Table 2A** These will be the results for the "no treatment" batteries.

**b) Continuous stirring with straw**

Experimental measurements will be repeated as described above by stirring the electrolytic solution with straw to note open circuit voltage.

And also short-circuit-current for every one minute over 3 minutes. The results are noted as in **Table 2B**

**c) Continuous blowing bubbles with straw**

Above experiment will be repeated, but this time instead of stirring the electrolyte with the straw, the straw will be used to blow bubbles into the solution. The results are noted as in **Table 2C**

While blowing, the straw has to be held close to the copper electrode, as this is where the dissolved oxygen get reduced.

**Short circuiting to observe the impact of solution on electrodes:**

After finishing, to visualise a more obvious electrode change, the salt water battery will be run for longer in short-circuit mode. For this, free ends of the red and black alligator clips will be connected directly to each other. After two days, the electrode will be taken out and examined for the condition again and record it in **Table:1**

**It is proposed to collect DATA as given in TABLES**

**TABLE 1: COMPARING ELECTRODE CONDITIONS AT THE BEGINNING AND**

Metal Electrodes	Cathode (Cu)				Anode(Zn)			
	SW	SW+L Cu	SW+O Cu	SW+ T Cu	SW	SW+L Zn	SW+O Zn	SW+ T Zn
<b>Electrode Condition at the Beginning</b>								
Weight (in g)								
Colour								
Surface roughness								
Lusture								
<b>Electrode Condition at the End</b>								
Weight (in g)								
Colour								
Surface roughness								
Lusture								

**END OF THE EXPERIMENT**

**TABLE 2. OPEN-CIRCUIT VOLTAGE AND SHORT-CIRCUIT CURRENT FOR DIFFERENT ELECTROLYTES UNDER DIFFERENT EXPERIMENTAL CONDITIONS**

**TABLE 2A: WORKING OF FRUIT-SALT COMBO WITHOUT ANY TREATMENT**

Electrolyte	Without any mechanical treatment					
	Open circuit voltage (V)	Closed circuit current (I)				
		At once	After 1 min	After 2 min	After 3 min	Average
Salt Water						
Lemon Added Salt Water						
Orange Added Salt Water						
Tomoto Added						

Salt Water						
------------	--	--	--	--	--	--

**TABLE 2B: WORKING OF CONTINUOUSLY STIRRED FRUIT-SALT COMBO**

Electrolyte	Without any mechanical treatment					
	Open circuit voltage (V)	Closed circuit current (I)				
		At once	After 1 min	After 2 min	After 3 min	Average
Salt Water						
Lemon Added Salt Water						
Orange Added Salt Water						
Tomoto Added Salt Water						

**TABLE 2C: WORKING OF CONTINUOUSLY BLOWN FRUIT-SALT COMBO**

Electrolyte	Without any mechanical treatment					
	Open circuit voltage (V)	Closed circuit Current (I)				
		At once	After 1 min	After 2 min	After 3 min	Average
Salt Water						
Lemon Added Salt Water						
Orange Added Salt Water						
Tomoto Added Salt Water						

**TABLE 3 A: COMPARING OPEN-CIRCUIT VOLTAGE OF FRUIT COMBOS AT DIFFERENT EXPERIMENTAL CONDITIONS**

Electrolyte	Open circuit voltage(V)		
	No Treatment	Continous stirring with straw	Continous blowing bubbles with straw
Salt Water			
Lemon added salt water			
Orange added salt water			
Tomoto added salt water			

**TABLE 3 B : COMPARING CLOSED-CIRCUIT CURRENT OF FRUIT COMBOS AT DIFFERENT EXPERIMENTAL CONDITIONS**

Electrolyte	Closed Circuit Current (I)		
	No Treatment	Continous stirring with straw	Continous blowing bubbles with straw
Salt Water			
Lemon added salt water			
Orange added salt water			
Tomoto added salt water			

**Graphical Representation:**

All tabulated data will be graphically presented

**F. Bibliography:**

**REFERENCES**

- <https://sciencing.com/do-citrus-fruits-produce-electricity-5167602.html>
- <https://www.electrical4u.com/battery-working-principle-of-batteries/>

- <http://www.upsbatterycenter.com/blog/electrolyte-battery-2/#prettyPhoto>
- <https://www.thoughtco.com/how-to-make-a-fruit-battery-605970>
- <https://www.scientificamerican.com/article/generate-electricity-with-a-lemon-battery/>
- <https://www.advancedsciencenews.com/salt-water-battery/>
- <https://sciencing.com/light-lightbulb-saltwater-8523885.html>
- <https://sciencing.com/do-citrus-fruits-produce-electricity-5167602.html>